

GDM12232A-NSW-BBW

SPECIFICATIONS OF LCD MODULE

Features

- 1、 Full dot-matrix structure with 122 x 32 dots
- 2、 Built-in controller (AX6120DOA or Equivalent)
- 3、 Power supply VDD=5V
- 4、 1/32 duty ,1/6 bias
- 5、 STN, negative, transmissive,
- 6、 LED Side light (White)
- 7、 6 o'clock viewing angle
- 8、 8 bits parallel data input

Mechanical diagram (Unit: mm)

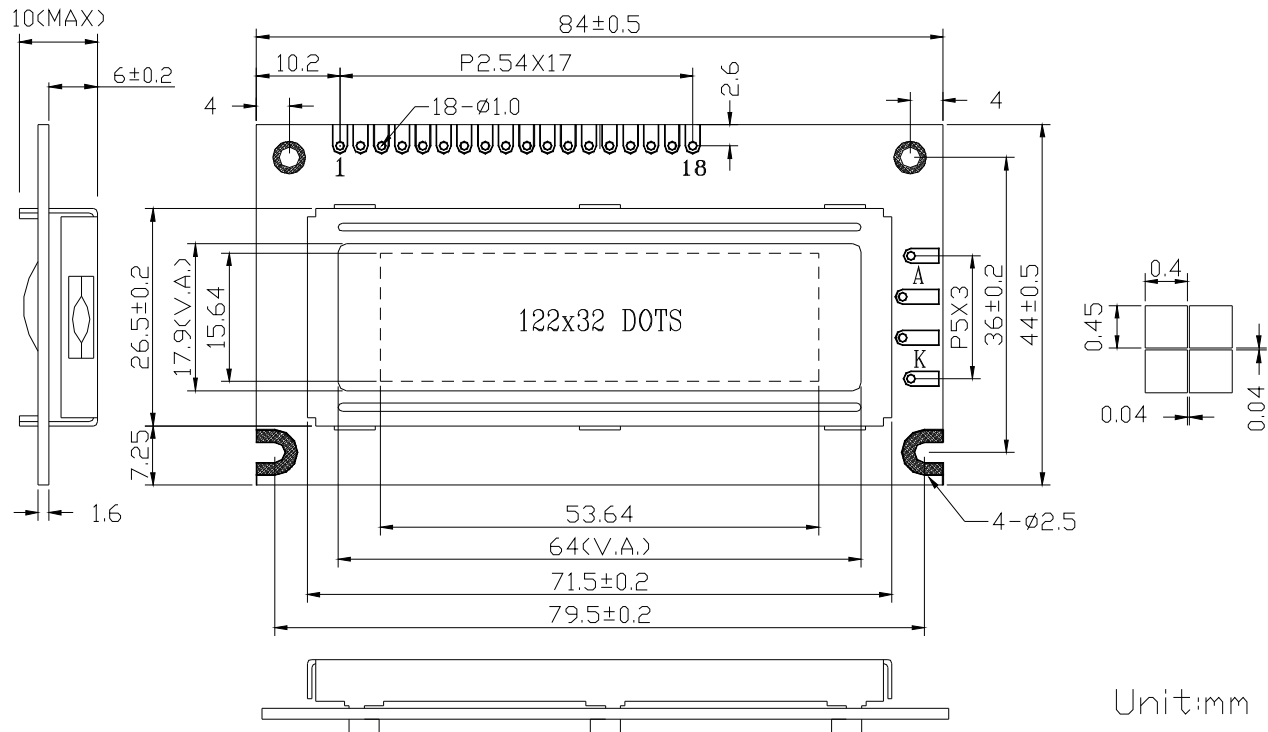

Absolute Maximum Ratings

Item	Symbol	Min	Max	Unit
Power Voltage	V _{DD} -V _{SS}	0	7.0	V
Input Voltage	V _O	V _{SS}	V _{DD}	
Operating Temperature Range	T _{OP}	-20	+70	°C
Storage Temperature Range	T _{ST}	-30	+80	

Block diagram

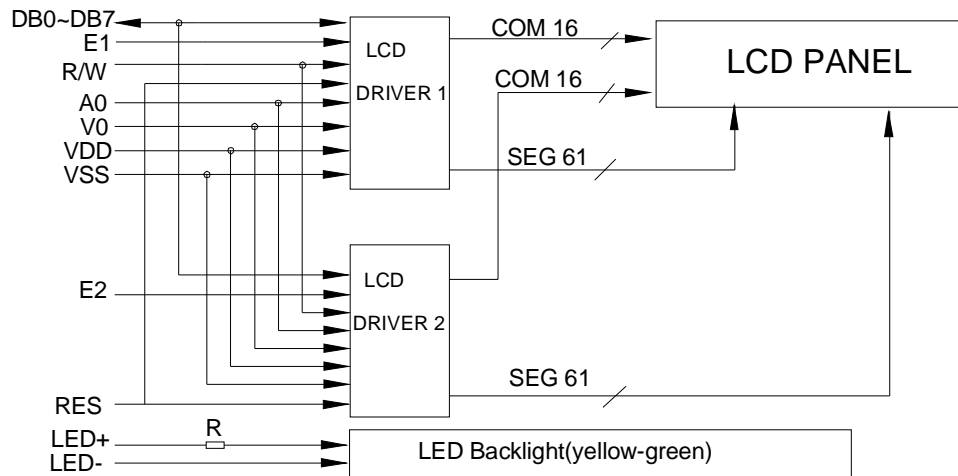

Description Of Terminals

Pin No.	Pin Name	Input/Output	External Connection	Function
1	VSS	—	Power Supply	Signal ground for LCM
2	VDD	—		VDD: +5V
3	VO	—		V_{LCD} adjustment
4	RST	Output	MPU	Reset signal
5	E1	Input	MPU	Chip enable active "L", SEG(1~61)
6	E2	Input	MPU	Chip enable active "L", SEG(62~122)
7	R/W	Input	MPU	Read/write select signal "0" for writing, "1" for reading
8	A0	Input	MPU	Register select input "0": Instruction register (when writing) Busy flag address counter (When reading) "1": Data register (when writing & reading)
9~16	DB0-DB7	Input/output	MPU	Data bus [0~7] Bi-directional data bus
17	LED+	—	LED BK	Power supply for BKL (+5.0V)
18	LED-	—	Power supply	Power supply for BKL (GND)

Contrast adjust

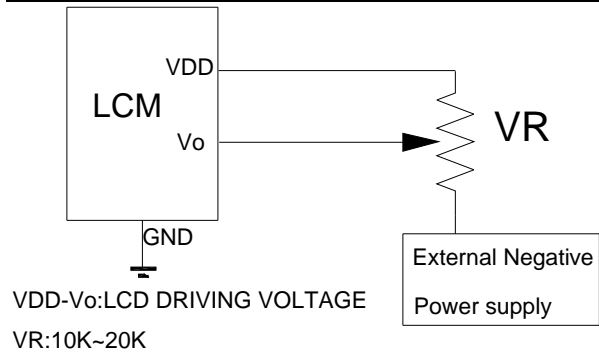

Optical characteristics

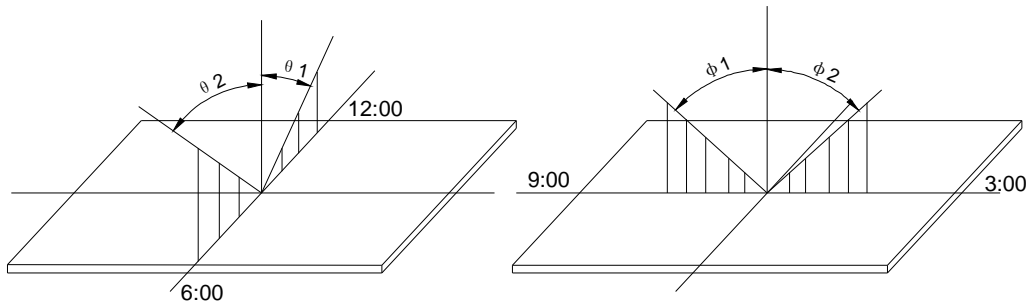

STN type display module (Ta=25°C, VDD=5.0V)

Item	Symbol	Condition	Min.	Typ.	Max.	Unit
Viewing angle	$\theta 1$	$C_r \geq 3$		20		deg
	$\theta 2$			40		
	$\Phi 1$			35		
	$\Phi 2$			35		
Contrast ratio	C_r		-	6	-	-
Response time (rise)	T_r	-	-	200	250	ms
Response time (fall)	T_r	-	-	300	350	

Electrical characteristics

LED backlight circuit (color: white)

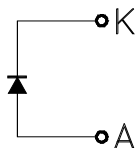

LED ratings

ITEM	SYMBOL	MIN	TYP.	MAX	UNIT
FORWARD VOLTAGE	VF	2.9	3.1	3.4	V
FORWARD CURRENT	IF	-	13	20	MA
POWER	P	-	-	0.2	W
PEAK WAVE LENGTH	λP	-	-	-	NM
LUMINANCE	LV	-	200	-	CD/M2
Operating temperature range	VOP	-20	-	+70	

Storage temperature range	VST	-25	-	+80	
---------------------------	-----	-----	---	-----	--

DC characteristics

Parameter	Symbol	Conditions	Min.	Typ.	Max.	Unit
Supply voltage for LCD	$V_{DD}-V_0$	$T_a = 25^\circ\text{C}$	-	6.5	-	V
Input voltage	V_{DD}		4.8	5.0	5.3	
Backlight supply voltage	V_F		-		5.0	
Supply current	I_{DD}	$T_a = 25^\circ\text{C}, V_{DD} = 5.0\text{V}$	-	1.5	2.5	mA
Backlight supply current	I_F	$V = 5.0\text{V}, R = 150\ \text{ohm}$	-	13	20	
Input leakage current	I_{LKG}		-	-	1.0	μA
"H" level input voltage	V_{IH}		2.2	-	V_{DD}	V
"L" level input voltage	V_{IL}	Twice initial value or less	0	-	0.6	
"H" level output voltage	V_{OH}	$LOH = -0.25\text{mA}$	2.4	-	-	
"L" level output voltage	V_{OL}	$LOH = 1.6\text{mA}$	-	-	0.4	

Timing Characteristics

MPU bus read/write 1(80-family MPU)

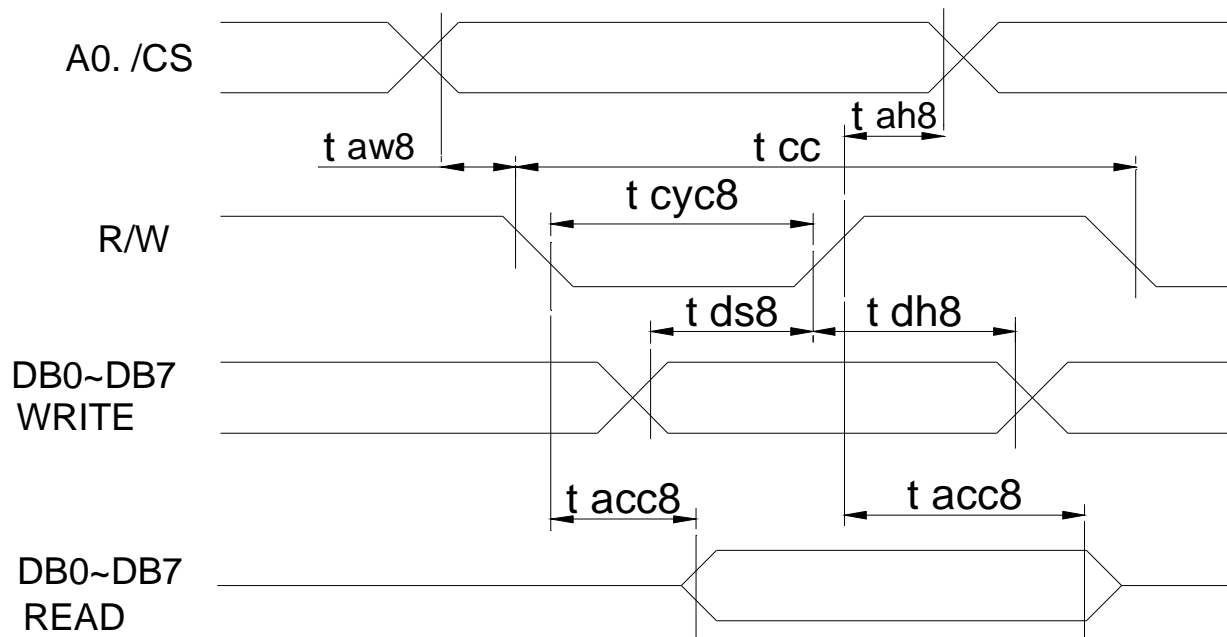

Item	symbol	Conditions	Min.	Max.	unit
System cycle time	t_{cyc}	—	1000	—	ns
Address setup time	t_{aw8}	—	20	—	ns
Address hold time	t_{ah8}	—	10	—	ns
Data setup time	t_{ds8}	—	80	—	ns
Data hold time	t_{dh8}	—	10	—	ns
Control pulse width	t_{cc8}	—	200	—	ns
RD access time	t_{cc8}	$CL = 100\text{pf}$	—	90	ns

Output disable time	t ch8		10	60	ns
---------------------	-------	--	----	----	----

MPU bus read/write 2(68-family MPU)

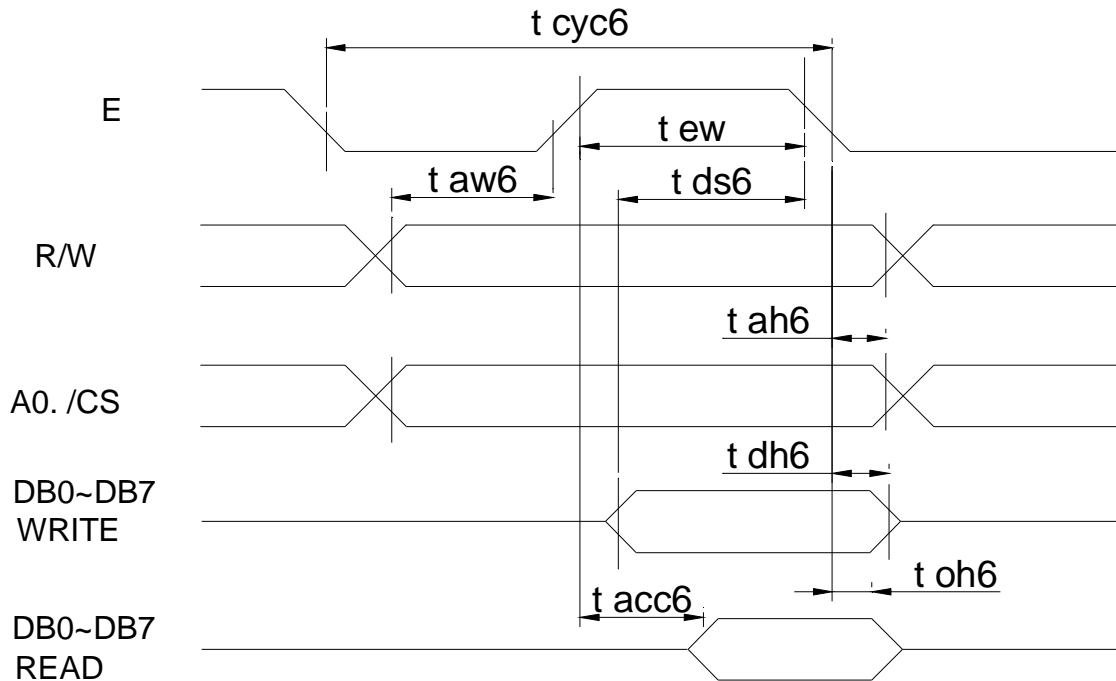

Item	symbol	Conditions	Min.	Max.	unit
System cycle time	t cyc6	—	1000	—	ns
Address setup time	t aw6	—	20	—	ns
Address hold time	t ah6	—	10	—	ns
Data setup time	t ds6	—	80	—	ns
Data hold time	t dh6	—	10	—	ns
Access time	t acc6	CL=100pf	—	90	ns
Output disable time	t oh6		10	60	ns
Enable pulse width	Read	t ew	—	100	ns
			Write	—	80

Display command

Parameter	A0	E	RW	D7	D6	D5	D4	D3	D2	D1	D0	Note
Display ON /OFF	0	1	0	1	0	1	0	1	1	1	0/1	Turns display on or off 1: ON ; 0 : OFF

Display start line	0	1	0	1	1	0	Display start address (0 to 31)				Specifies RAM line corresponding to top line of display	
Set page address	0	1	0	1	0	1	1	1	0	Page (0 to 3)		Sets display RAM page in page address register
Set column (segment) address	0	1	0	0	Column address (0 to 79)							Sets display RAM column address in column address register
Read status	0	0	1	Busy	ADC	ON/OFF	RESET	0	0	0	0	Reads the following status: BUSY 1: Busy 0: Ready ADC 1: CW output 0: CCW output ON/OFF 1: Display off 0: Display on RESET 1: Being reset 0: Normal
Write display data	1	1	0	Write data							Write data from data bus into display RAM	
Read Display data	1	0	1	Read data							Read data from display RAM onto data bus	
Select ADC	0	1	0	1	0	1	0	0	0	0	0/1	0: CW output 1: CCW output
Static driver ON/OFF	0	1	0	1	0	1	0	0	1	0	0/1	Selects static driving operation. 1: static driver, 0: Normal driving
Select duty	0	1	0	1	0	1	0	1	0	0	0/1	Select LCD duty cycle 1: 1/32, 0: 1/16
Read-modify write	0	1	0	1	1	1	0	0	0	0	0	Read-modify-write ON
End	0	1	0	1	1	1	0	1	1	1	0	Read-modify-write OFF
Reset	0	1	0	1	1	1	0	0	0	1	0	Software reset

Note: The AX6120 series identifies a data bus using a combination of A0 and R/W (RD or WR signals). As the MPU translates a command in the internal timing only (independent from the external clock). Its speed is very high. The busy check is usually not required.

Display ON/OFF (AEH, AFH)

A0	E (RD)	R/W (/WR)	D7	D6	D5	D4	D3	D2	D1	D0
0	1	0	1	0	1	0	1	1	1	D

The command turns the display on and off
D=1: display ON D=0: display OFF

Display start line (C0H~DFH)

This command specifies the line address and indicates the display line that corresponds to COM0. The display area begins at the specified line address and continues the line address increment direction. This area having the number of lines of the specified display duty is displayed. If the line address is changed dynamically by this command the vertical smooth scrolling and paging can be used.

A0	E (RD)	R/W (/WR)	D7	D6	D5	D4	D3	D2	D1	D0
----	--------	-----------	----	----	----	----	----	----	----	----

0	1	0	1	1	0	A4	A3	A2	A1	A0
---	---	---	---	---	---	----	----	----	----	----

This command loads the display start line register.

A4	A3	A2	A1	A0	Line address
0	0	0	0	0	0
0	0	0	0	1	1
/	/	/	/	/	/
1	1	1	1	1	1F

Set page address (B8H~BBH)

This command specifies the page address that corresponds to the low address of the display data RAM when it is accessed by the MPU. Any bit of the display data RAM can be accessed when its page address and column address are specified. The display status is not changed even when the page address is changed.

A0	E (RD)	R/W (/WR)	D7	D6	D5	D4	D3	D2	D1	D0
0	1	0	1	0	1	1	1	0	A1	A0

This command loads the page address register.

A1	A0	Page
0	0	0
0	1	1
1	0	2
1	1	3

Set column address (00H~4FH)

This command specifies a column address of the display data RAM. When the display data RAM is accessed by the MPU continuously, the column address is incremented by 1 each time it is accessed from the set address. Therefore, the MPU can access to data continuously. The column address stops to be incremented at address 80, and the page address is not changed continuously.

A0	E (RD)	R/W (/WR)	D7	D6	D5	D4	D3	D2	D1	D0
0	1	0	0	A6	A5	A4	A3	A2	A1	A0

This command loads the column address register.

A6	A5	A4	A3	A2	A1	A0	Column address
0	0	0	0	0	0	0	0
0	0	0	0	0	0	1	1

/	/	/	/	/	/	/	/
1	0	0	1	1	1	1	4F

Read status

A0	E (RD)	R/W (WR)	D7	D6	D5	D4	D3	D2	D1	D0
0	1	0	Busy	ADC	On/off	Reset	A3	A2	A1	A0

Reading the command I/O register (A0=0) yields system status information.

The busy bit indicates whether the driver will accept a command or not.

Busy=1: the driver is currently executing a command or is resetting. No new command will be accepted.

Busy=0: the driver will accept a new command.

The ADC bit indicates the way column addresses are assigned to segment drivers.

ADC=1 Normal. Column address n → segment driver n.

ADC=0 Inverted. Column address 79 u → segment driver u.

The ON/OFF bit indicates the current status of the display.

It is the inverse of the polarity of the display ON/OFF command.

ON/OFF=1: display off

ON/OFF=0: display on

The RESET bit indicates whether the driver is executing a hardware or software reset or if it is in normal operating mode.

Reset=1: currently executing reset command.

Reset=0: normal operation

Write display data

A0	E (RD)	R/W (WR)	D7	D6	D5	D4	D3	D2	D1	D0
1	1	0	Write data							

Writes 8-bit of data into the display data RAM, at a location specified by the contents of the column address and page address registers and then increments the column address register by one.

Read display data

A0	E (RD)	R/W (WR)	D7	D6	D5	D4	D3	D2	D1	D0
1	0	1	Read data							

Reads 8-bit of data from the data I/O latch, updates the contents of the I/O latch with display data from the display data RAM location specified by the contents of the column address and page address registers and then increments the column address register.

After loading a new address into the column address register one dummy read is required before valid data is obtained.

Select ADC (A0H, A1H)

A0	E (RD)	R/W (/WR)	D7	D6	D5	D4	D3	D2	D1	D0
0	1	0	1	0	1	0	0	0	0	D

This command selects the relationship between display data RAM column addresses and segment drivers.

D=1: SEG0 ← column address 4FH,4EH...00H(inverted).

D=0: SEG0 ← column address 00H,01H...4FH(normal).

This command is provided to reduce restrictions on the placement of driver ICs and routing of traces during printed circuit board design.

Static drive ON/OFF (A4H, A5H)

A0	E (RD)	R/W (/WR)	D7	D6	D5	D4	D3	D2	D1	D0
0	1	0	1	0	1	0	0	1	0	D

Forces display on and all common outputs to be selected.

D=1:static drive on

D=0:static drive off

Select duty (A8H; A9H)

A0	E (RD)	R/W (/WR)	D7	D6	D5	D4	D3	D2	D1	D0
0	1	0	1	0	1	0	1	0	0	D

This command sets the duty cycle of the LCD drive and is only valid for the AX6120F and AX6122F.it is invalid for the AX6121F, which performs passive operation. The duty cycle of the AX6121F is determined by the externally generated FR signal.

AX6120 AX6122

D=: 1/32 duty cycle 1/16 duty cycle

D=: 1/16 duty cycle 1/8 duty cycle

When using the AX6120F0A, AX6122F0A (having a built-in oscillator) and the AX6121F0A continuously, set the duty as follows:

		AX6121FOA
AX6120FOA	1/32	1/32
	1/16	1/16
AX6122FOA	1/116	1/32
	1/8	1/16

READ-MODIFY-WRITE (E0H)

A0	E (RD)	R/W (/WR)	D7	D6	D5	D4	D3	D2	D1	D0
0	1	0	1	1	1	0	0	0	0	0

This command defeats column address register auto-increment after data reads. The current contents of the column address register are saved. This mode remains active until an end command is repeated. Operation sequence during cursor display

When the end command is entered, the column address is returned to the one used during input of read-modify-write command. This function can reduce the load of MPU when data change is repeated at a specific Display area (such as cursor blinking).

*Any command other than data read or write can be used in the read-modify-write mode. However, the column address set command cannot be used.

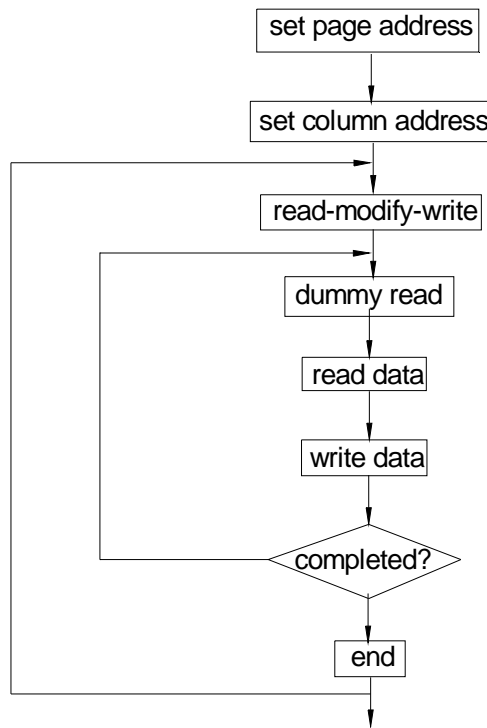

END (EEH)

A0	E (RD)	R/W (/WR)	D7	D6	D5	D4	D3	D2	D1	D0
0	1	0	1	1	1	0	1	1	1	0

This command cancels read-modify-write mode and restores the contents of the column address register to their value prior to the receipt of the read-modify-write command.

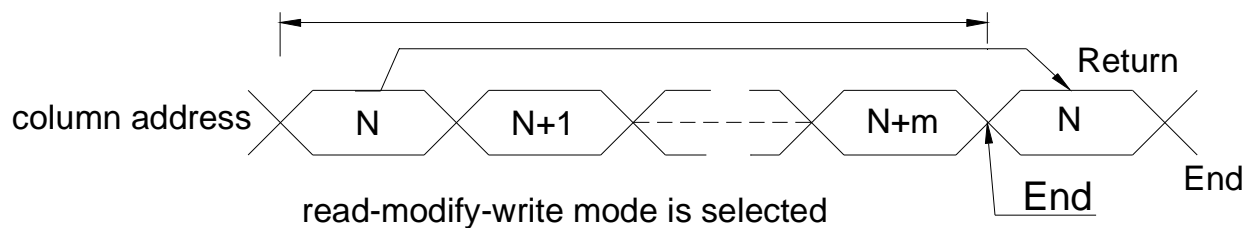

RESET (E2H)

A0	E (RD)	R/W (/WR)	D7	D6	D5	D4	D3	D2	D1	D0
0	1	0	1	1	1	0	1	1	1	0

This command clears

The display start line register.

And set page address register to 3 page.

It does not affect the contents of the display data RAM.

QUALITY SPECIFICATIONS

1 Standard of the product appearance test

Manner of appearance test: The inspection should be performed in using 20W x 2 fluorescent lamps. Distance between LCM and fluorescent lamps should be 100 cm or more. Distance between LCM and inspector eyes should be 25 cm or more.

Viewing direction for inspection is 35° from vertical against LCM.

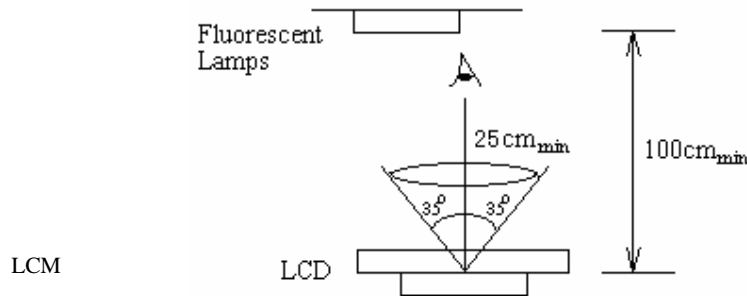

Definition of zone:

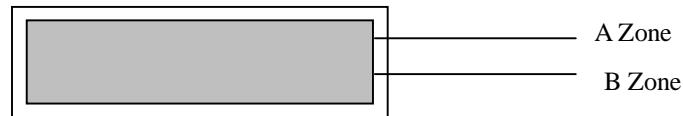

A Zone: Active display area (minimum viewing area).

B Zone: Non-active display area (outside viewing area).

2 Specification of quality assurance

AQL inspection standard

Sampling method: GB2828-87, Level II, single sampling

Defect classification (**Note: * is not including**)

Classify		Item	Note	AQL
Major	Display state	Short or open circuit	1	0.65
		LC leakage		
		Flickering		
		No display		
		Wrong viewing direction	2	
		Contrast defect (dim, ghost)		
		Backlight		
Non-display	Flat cable or pin reverse	10		
	Wrong or missing component	11		
Minor	Display state	Background color deviation	2	1.0
		Black spot and dust	3	
		Line defect, Scratch	4	
		Rainbow	5	

GDM12232A-NSW-BBW

		Chip	6
		Pin hole	7
		Protruded	12
	Polarizer	Bubble and foreign material	3
	Soldering	Poor connection	9
	Wire	Poor connection	10
	TAB	Position, Bonding strength	13

Note on defect classification

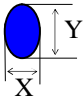
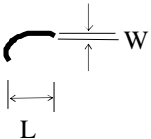
No.	Item	Criterion												
1	Short or open circuit	Not allow												
	LC leakage													
	Flickering													
	No display													
	Wrong viewing direction													
	Wrong Back-light													
2	Contrast defect	Refer to approval sample												
	Background color deviation													
3	Point defect, Black spot, dust (including Polarizer) $\phi = (X+Y)/2$	 <table border="1" data-bbox="873 840 1279 1073"> <thead> <tr> <th>Point Size</th> <th>Acceptable Qty.</th> </tr> </thead> <tbody> <tr> <td>$\phi \leq 0.10$</td> <td>Disregard</td> </tr> <tr> <td>$0.10 < \phi \leq 0.15$</td> <td>2</td> </tr> <tr> <td>$0.15 < \phi \leq 0.25$</td> <td>1</td> </tr> <tr> <td>$\phi > 0.25$</td> <td>0</td> </tr> </tbody> </table> <p style="text-align: center;">Unit: Inch²</p>	Point Size	Acceptable Qty.	$\phi \leq 0.10$	Disregard	$0.10 < \phi \leq 0.15$	2	$0.15 < \phi \leq 0.25$	1	$\phi > 0.25$	0		
Point Size	Acceptable Qty.													
$\phi \leq 0.10$	Disregard													
$0.10 < \phi \leq 0.15$	2													
$0.15 < \phi \leq 0.25$	1													
$\phi > 0.25$	0													
4	Line defect, Scratch	 <table border="1" data-bbox="808 1287 1318 1455"> <thead> <tr> <th colspan="2">Line</th> <th rowspan="2">Acceptable Qty.</th> </tr> <tr> <th>L</th> <th>W</th> </tr> </thead> <tbody> <tr> <td>---</td> <td>$0.05 > W$</td> <td rowspan="3">Disregard</td> </tr> <tr> <td>$3.0 > L$</td> <td>$0.1 > W > 0.05$</td> </tr> <tr> <td>$2.0 > L$</td> <td>$0.15 \geq W > 0.1$</td> </tr> </tbody> </table> <p style="text-align: center;">Unit: mm</p>	Line		Acceptable Qty.	L	W	---	$0.05 > W$	Disregard	$3.0 > L$	$0.1 > W > 0.05$	$2.0 > L$	$0.15 \geq W > 0.1$
Line		Acceptable Qty.												
L	W													
---	$0.05 > W$	Disregard												
$3.0 > L$	$0.1 > W > 0.05$													
$2.0 > L$	$0.15 \geq W > 0.1$													
5	Rainbow	Not more than two color changes across the viewing area.												

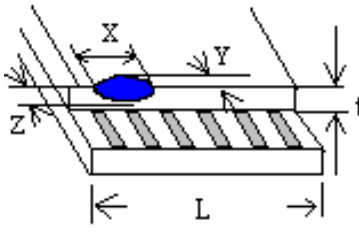
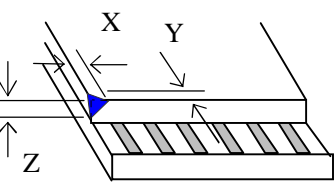
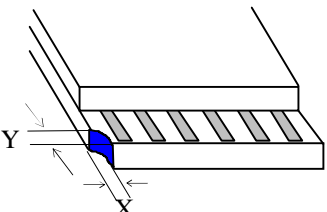
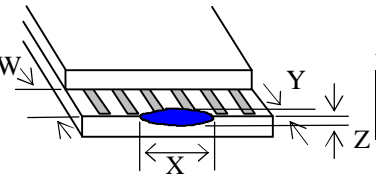
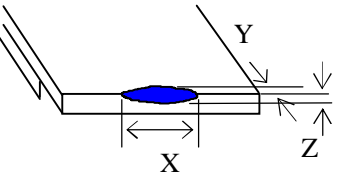
No	Item	Criterion																																	
6	<p>Chip</p> <p>Remark: X: Length direction Y: Short direction Z: Thickness direction t: Glass thickness W: Terminal width L: Glass length</p>	 <p>Acceptable criterion</p> <table border="1" data-bbox="933 346 1307 430"> <thead> <tr> <th>X</th> <th>Y</th> <th>Z</th> </tr> </thead> <tbody> <tr> <td>$< L/8$</td> <td>0.5mm</td> <td>$\leq t/2$</td> </tr> </tbody> </table>  <p>Acceptable criterion</p> <table border="1" data-bbox="933 640 1307 724"> <thead> <tr> <th>X</th> <th>Y</th> <th>Z</th> </tr> </thead> <tbody> <tr> <td>≤ 2</td> <td>0.5mm</td> <td>$\leq t$</td> </tr> </tbody> </table>  <p>Acceptable criterion</p> <table border="1" data-bbox="933 913 1307 1029"> <thead> <tr> <th>X</th> <th>Y</th> <th>Z</th> </tr> </thead> <tbody> <tr> <td>≤ 3</td> <td>≤ 2</td> <td>$\leq t$</td> </tr> <tr> <td colspan="2">shall not reach to ITO</td> <td></td> </tr> </tbody> </table>  <p>Acceptable criterion</p> <table border="1" data-bbox="933 1270 1307 1354"> <thead> <tr> <th>X</th> <th>Y</th> <th>Z</th> </tr> </thead> <tbody> <tr> <td>Disregard</td> <td>≤ 0.2</td> <td>$\leq t$</td> </tr> </tbody> </table>  <p>Acceptable criterion</p> <table border="1" data-bbox="933 1543 1274 1627"> <thead> <tr> <th>X</th> <th>Y</th> <th>Z</th> </tr> </thead> <tbody> <tr> <td>≤ 5</td> <td>≤ 2</td> <td>$\leq t/3$</td> </tr> </tbody> </table>	X	Y	Z	$< L/8$	0.5mm	$\leq t/2$	X	Y	Z	≤ 2	0.5mm	$\leq t$	X	Y	Z	≤ 3	≤ 2	$\leq t$	shall not reach to ITO			X	Y	Z	Disregard	≤ 0.2	$\leq t$	X	Y	Z	≤ 5	≤ 2	$\leq t/3$
X	Y	Z																																	
$< L/8$	0.5mm	$\leq t/2$																																	
X	Y	Z																																	
≤ 2	0.5mm	$\leq t$																																	
X	Y	Z																																	
≤ 3	≤ 2	$\leq t$																																	
shall not reach to ITO																																			
X	Y	Z																																	
Disregard	≤ 0.2	$\leq t$																																	
X	Y	Z																																	
≤ 5	≤ 2	$\leq t/3$																																	

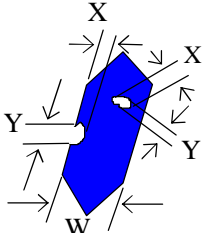
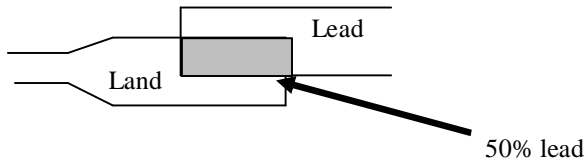
No.	Item	Criterion								
7	Segment pattern $W = \text{Segment width}$ $\phi = (X+Y)/2$	(1) Pin hole $\phi < 0.10\text{mm}$ is acceptable.  <table border="1" data-bbox="868 483 1295 646"> <thead> <tr> <th>Point Size</th> <th>Acceptable Qty</th> </tr> </thead> <tbody> <tr> <td>$\phi \leq 1/4W$</td> <td>Disregard</td> </tr> <tr> <td>$1/4W < \phi \leq 1/2W$</td> <td>1</td> </tr> <tr> <td>$\phi > 1/2W$</td> <td>0</td> </tr> </tbody> </table> <p style="text-align: right;">Unit: mm</p>	Point Size	Acceptable Qty	$\phi \leq 1/4W$	Disregard	$1/4W < \phi \leq 1/2W$	1	$\phi > 1/2W$	0
Point Size	Acceptable Qty									
$\phi \leq 1/4W$	Disregard									
$1/4W < \phi \leq 1/2W$	1									
$\phi > 1/2W$	0									
8	Back-light	(1) The color of backlight should be in match with the specification. (2) Not allow flickering								
9	Soldering	(1) Not allow heavy dirty and solder ball on PCB. (The size of dirty refer to point and dust defect) (2) Over 50% of lead should be soldered on Land. 								
10	Wire	(1) Copper wire should not be rusted (2) Not allow crack on copper wire connection. (3) Not allow reversing the position of the flat cable. (4) Not allow exposed copper wire inside the flat cable.								
11*	PCB	(1) Not allow screw rust or damage. (2) Not allow missing or wrong putting of component.								

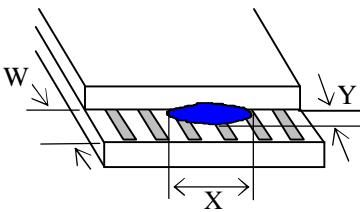
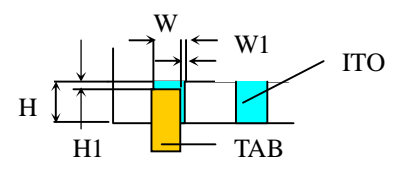
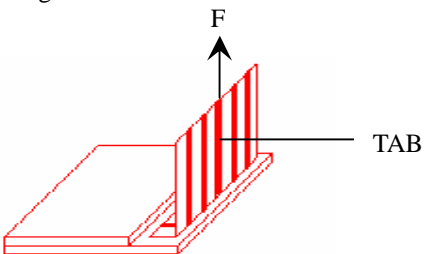
No	Item	Criterion
12	Protruded W: Terminal Width	 <p>Acceptable criteria: $Y \leq 0.4$</p>
13	TAB	<p>1. Position</p>  <div style="border: 1px solid black; padding: 5px; width: fit-content; margin-left: auto;"> $W1 \leq 1/3W$ $H1 \leq 1/3H$ </div> <p>2. TAB bonding strength test</p>  <p> $P (=F/TAB \text{ bonding width}) \geq 650\text{gf/cm}$,(speed rate: 1mm/min) 5pcs per SOA (shipment) </p>
14	Total no. of acceptable Defect	<p>A. Zone</p> <p>Maximum 2 minor non-conformities per one unit. Defect distance: each point to be separated over 10mm</p> <p>B. Zone</p> <p>It is acceptable when it is no trouble for quality and assembly in customer's end product.</p>

3 Reliability of LCM

Reliability test condition:

Item	Condition	Time (hrs)	Assessment
High temp. Storage	80°C	48	No abnormalities in functions and appearance
High temp. Operating	70°C	48	
Low temp. Storage	-30°C	48	
Low temp. Operating	-20°C	48	
Humidity	40°C/ 90%RH	48	
Temp. Cycle	0°C ← 25°C → 50°C (30 min ← 5 min → 30min)	10cycles	

Recovery time should be 24 hours minimum. Moreover, functions, performance and appearance shall be free from remarkable deterioration within 50,000 hours under ordinary operating and storage conditions room temperature (20±8°C), normal humidity (below 65% RH), and in the area not exposed to direct sun light.

4 Precaution for using LCD/LCM

LCD/LCM is assembled and adjusted with a high degree of precision. Do not attempt to make any alteration or modification. The followings should be noted.

General Precautions:

1. LCD panel is made of glass. Avoid excessive mechanical shock or applying strong pressure onto the surface of display area.
2. The polarizer used on the display surface is easily scratched and damaged. Extreme care should be taken when handling. To clean dust or dirt off the display surface, wipe gently with cotton, or other soft material soaked with isopropyl alcohol, ethyl alcohol or trichlorotrifluoroethane, do not use water, ketone or aromatics and never scrub hard.
3. Do not tamper in any way with the tabs on the metal frame.
4. Do not make any modification on the PCB without consulting XIAMEM OCULAR
5. When mounting a LCM, make sure that the PCB is not under any stress such as bending or twisting. Elastomer contacts are very delicate and missing pixels could result from slight dislocation of any of the elements.
6. Avoid pressing on the metal bezel, otherwise the elastomer connector could be deformed and lose contact, resulting in missing pixels and also cause rainbow on the display.
7. Be careful not to touch or swallow liquid crystal that might leak from a damaged cell. Any liquid crystal spreads to skin or clothes, wash it off immediately with soap and water.

Static Electricity Precautions:

1. CMOS-LSI is used for the module circuit; therefore operators should be grounded whenever he/she comes into contact with the module.
2. Do not touch any of the conductive parts such as the LSI pads; the copper leads on the PCB and the interface terminals with any parts of the human body.

3. Do not touch the connection terminals of the display with bare hand; it will cause disconnection or defective insulation of terminals.
4. The modules should be kept in anti-static bags or other containers resistant to static for storage.
5. Only properly grounded soldering irons should be used.
6. If an electric screwdriver is used, it should be grounded and shielded to prevent sparks.
7. The normal static prevention measures should be observed for work clothes and working benches.
8. Since dry air is inductive to static, a relative humidity of 50-60% is recommended.

Soldering Precautions:

1. Soldering should be performed only on the I/O terminals.
2. Use soldering irons with proper grounding and no leakage.
3. Soldering temperature: $280^{\circ}\text{C} \pm 10^{\circ}\text{C}$
4. Soldering time: 3 to 4 second.
5. Use eutectic solder with resin flux filling.
6. If flux is used, the LCD surface should be protected to avoid spattering flux.
7. Flux residue should be removed.

Operation Precautions:

1. The viewing angle can be adjusted by varying the LCD driving voltage V_o .
2. Since applied DC voltage causes electro-chemical reactions, which deteriorate the display, the applied pulse waveform should be a symmetric waveform such that no DC component remains. Be sure to use the specified operating voltage.
3. Driving voltage should be kept within specified range; excess voltage will shorten display life.
4. Response time increases with decrease in temperature.
5. Display color may be affected at temperatures above its operational range.
6. Keep the temperature within the specified range usage and storage. Excessive temperature and humidity could cause polarization degradation, polarizer peel-off or generate bubbles.
7. For long-term storage over 40°C is required, the relative humidity should be kept below 60%, and avoid direct sunlight.